

QUALITY FILTERS, INC.

THINK **SIMPLE**. THINK **SMART**. THINK **QUALITY**.

23351 Grissom Drive
 Robertsdale, AL 36567
 www.QualityFilters.com

Phone: (251) 947-2400
 Order Fax: (251) 947-2499
 Sales Fax: (251) 947-7948

QUALITY SEAL - Paint Arrestor Media Multi-Pocket Polyester Cube Filters

Date 25 Jan 11	Dwg No.	Rev
Date 25 Jan 11	Q-110008	C

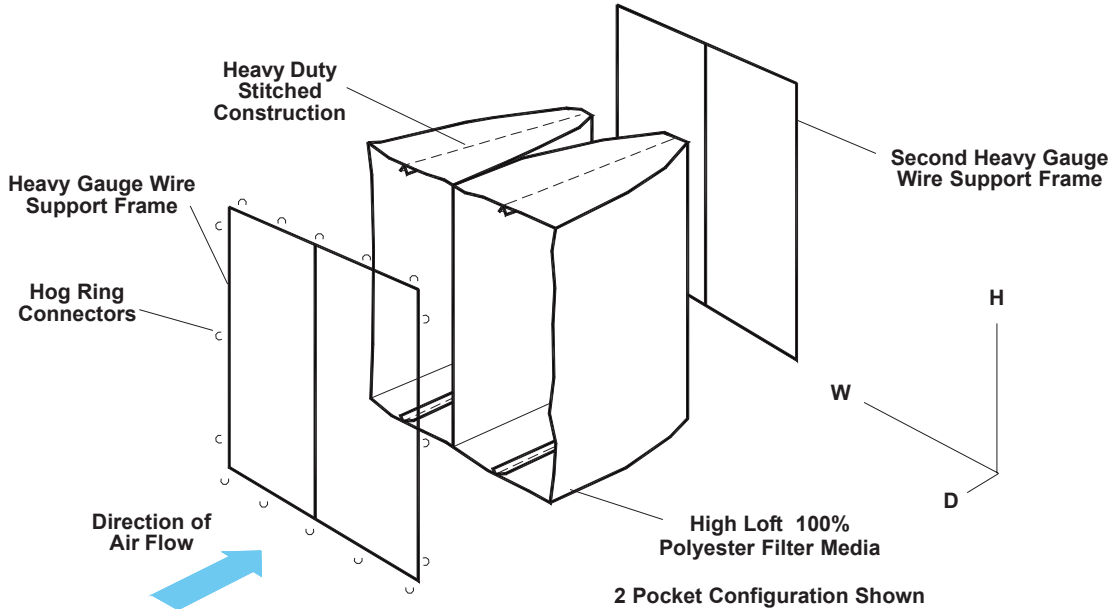

Notes:

Quality Seal Multi-Pocket Polyester Cube Filters offer up to five times the filter area of flat panels.

One, Two, and Three pocket configurations in any media or combination of medias are available.

Quality Seal Multi-Pocket Polyester Cube Filters are the best way to maximize the service life and efficiency of the "Quality Seal" polyester medias.

Double wire frame construction encapsulates the media, providing a self sealing support that also withstands warping from heavy loading and aggressive installation.

Polyester overlap around the edges inhibits dust and paint bypass. Ideal for HVAC or Paint Overspray collection.

Part Number Guide

Product Code	Pocket Count*	Media	Dimensions	Header	No Support Wire
CF	1	Paint Arrestor	WxHxD	H	X

Examples:
 CF1PA122412 = Cube Filter, 1 Pkt, Paint Arrestor Media, 12x24x12
 CF3PA202015H = Cube Filter, 3 Pkt, Paint Arrestor Media, 20x20x15, with Header
 *Q denotes 2 triangle shaped pockets

Typical Performance Data (24x24x12 - 2 Pocket Filter)

Product Code	ASHRAE 52.2 - 1999				Initial Resistance "w.g."	Final Resistance "w.g."
	MERV Value	E1 %	E2 %	E3 %	@ 300 fpm	@ 300 fpm
CF2PA	7*	n/a	n/a	n/a	0.045	1.00

*Minimum performance expectation - Test data pending.

Media Area (sq. ft.) Paint Arrestor Media

Face Dimensions w x h	1 Pkt Square Cubes			2 Pkt Tapered Cubes			
	Depth	12"	15"	20"	12"	15"	20"
12x24		8.00	9.50	12.00	-	-	-
16x20		8.22	9.72	12.22	8.67	10.83	14.44
16x25		9.61	11.32	14.17	10.33	12.92	17.22
20x20		9.44	11.11	13.89	9.17	11.46	15.28
20x24		10.67	12.50	15.56	10.50	13.13	17.50
20x25		10.97	12.85	15.97	10.83	13.54	18.06
24x24		12.00	14.00	17.33	11.00	13.75	18.33
Face Dimensions w x h	2 Pkt Triangular Cubes				3 Pkt Tapered Cubes		
	Depth	13"	14"	16"	18"	12"	15"
12x24	6.71	-	-	-	-	-	-
20x20		7.86	-	-	-	13.75	17.19
20x25			10.0	-	-	16.25	20.31
24x24				11.31	-	16.50	20.63

Characteristics	Quality Seal Multi-Pocket Cube Filters
Filter Media	1 inch thick; 15 and 40 denier dry polyester blend with calendered smooth downstream layer
Construction Technique	Sewn pockets with hog ring fasteners
Support Frames	Two 0.148 inch (9 gauge) galvanized steel wire frames
Max. Temperature	100°F (38°C) continuous service, Peaks 120°F (49°C)
Max. Humidity	Resistant to 100% R.H.